



CAMP TREETOPS
NORTH COUNTRY SCHOOL
ROCK-E HOUSE & BASECAMP



*Rotating drum composter
design guide*



CAMP TREETOPS NORTH COUNTRY SCHOOL ROCK-E HOUSE & BASECAMP

This document outlines how we designed and built a commercial-scale, rotating drum composter, capable of processing all of the unsorted food waste from our organization. We feed approximately 140 people, three times per day during the school session and approximately 250 people, three times per day for nine weeks during the summer. This composter was built for approximately \$15,000 in material cost. Similar-sized composters purchased on the open market range anywhere from \$40,000 to \$150,000. Our hope is that this document provides enough detail so that others may build their own composter, saving money, keeping food waste out of landfills, and generating a value product for use or sale. We are quite sure that modifications can be made to reduce the material and labor costs involved in construction.

A summary of particulars

- We have been continuously operating our composter since May of 2016, processing approximately 50,000 pounds of food waste and other organics per year. This does not include the carbon material necessary for the composting process.
- At the time of this writing (September 2019), there are five of these composters in operation at various schools and one nature center, all located in 40-foot shipping containers, or other buildings.
- All component parts for this composter can be found locally and most moderately trained personnel, with access to a moderately well-equipped maintenance shop can build this unit. (If your organization does not have the capacity, there are at least two local contractors close to our location who can build and ship them to your location.)
- The drum is made from a four-foot diameter, 20-foot long HDPE road culvert.
- Our composter is designed to stay ½ full all of the time.
- The weight of the food scraps and carbon bulking material when the drum is ½ full is approximately 3,300 pounds.
- We process anywhere from 50 to 250 pounds of food waste per day. The unit can easily accommodate over 400 pounds on occasion.
- All food waste can be processed in this unit, including meat and fats.
- For our carbon bulking material we have used wood chips, wood shavings, and wood pellets intended for pellet heating stoves. All of these have proven successful.
- Our unit is maintained by our middle-school age students during the academic year and our campus during the summer, with help from 1-2 adults.
- The time required to go from raw food waste to a stable (but still active) compost ranges from 25-45 days. After this time the compost smells like soil, does not attract dogs or vermin, and can be used directly in gardens as a top dressing, or allowed to cure for an additional couple of months to produce a fully finished compost.
- Our composter was built using an economic development grant from the New York State Energy Research and Development Authority (NYSERDA) with grant management provided by the Adirondack North Country Association (ANCA).
- The building where our composter is housed is minimally insulated and minimally heated.
- We are reaching design temperatures inside the composter of 110-140 °F.

Supplemental materials and technical consultation are available upon request including:

- Operating manual
- One-page talking points/summary
- Site host compatibility/feasibility
- Siting guidance document (including shipping container fit-up recommendations)
- Site visits/composter designer consultations

LIABILITY/DISCLAIMER: North Country School Camp Treetops, its agents and employees are not liable for any claims, actions, damages, losses, expenses and costs of every nature and kind, including attorney's fees, up to and through any and all appeals incurred by or asserted or imposed against North Country School Camp Treetops resulting from, arising out of or relating to the construction of a composter that follows the ensuing design document guidance. Manufacturers and site hosts assume all risks associated with construction, installation, and implementation of the drum compost system.

Document updated Jan. 8, 2020

JOHN CULPEPPER jculpepper@northcountryschool.org
NORTH COUNTRY SCHOOL AND CAMP TREETOPS

ROTARY COMPOSTER

CONSTRUCTION DISCLAIMER:

I have tried my best to provide accurate descriptions, manufacturer and part numbers for all of the component parts. If I have made a mistake then please let me know so that I can correct it. For some components I identified where the component was purchased. For others I simply identified the manufacturer of the component. Please feel free to make alterations in this design and share those with me. I am reasonably sure that others will find easier ways to put this together, and perhaps with less expensive, or different components. I would like to share improvements on this design with the rest of the world.

For those who are interested in this composter, but do not have the resources or skill to construct it, there is at least one contractor, close to our location who is able to construct the unit and ship to your location. Please let me know if you would like his contact information. — John Culpupper

Compost Discharge End (pg. 8-9)

End Cap and Door (pg. 10-11)

Frame (pg. 4-5)

Steel Band for Drive Wheel



Drive Wheel Assembly (pg. 6-7)

Motor Assembly (pg. 12-14)

ROTARY COMPOSTER

Framing



ABOVE: An example of the kind of shop needed for building one of these composters.

AT TOP: HDPE Culvert (Composter Drum), 4' diameter x 20' length, purchased locally.

NOTE: The diameter configuration of the ribs on the drum sometimes differ; adjustments may be needed to accommodate.

ROTARY COMPOSTER

Framing



1) 3"x 3"x ¼" End Plate

• Cut from 3" x ¼" flat stock steel and welded to the end of the 3" x 3" angle iron, with a hole drilled into it for the bolt.

2) 3"x 3"x ¼" Angle Iron

3) Two pieces of 8"x ¼" Flat Steel Rolled 54½" (+ or -)

*The steel bands were rolled into half circles at our local steel shop, then we welded the two half circles in place, on the drum. Alternately, tabs could be welded onto the ends of the half circles then the half circles bolted together.

NOTE: See corresponding diagram numbers on the last page for part information and quantities

ROTARY COMPOSTER

Drive Wheel Assembly

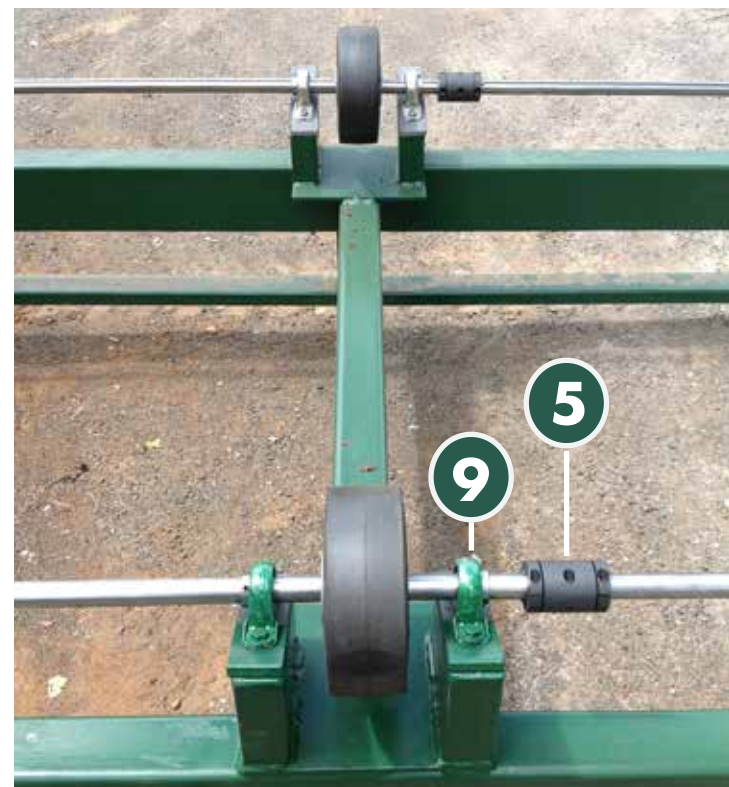

4) 1" Shaft with 1/4"x1/8" Full Keyway

5) High-Grip Clamp-On Rigid Shaft Coupling

(McMaster-Carr Part # 9800T14), shown painted and unpainted

6) 3"x 6" x 3/16" hollow structural steel

7) 3" wide rubber cover

- Protects the bearings from liquid leaking from the drum
- These can be cut from any durable, bendable material, and screwed into the C-channel with self tapping screws.

8) Drive Roller *(McMaster-Carr Part # 61065K17)*

9) Stamped-Steel Mounted Ball Bearing

(McMaster-Carr Part # 5913K64) 3)

- Bearing tolerance: ABEC-1
- 1" bore diameter to fit the fully-keyed steel drive shaft
- Attached to welded steel cap on C-shape structural steel

ROTARY COMPOSTER

Drive Wheel Assembly



4) Fully-Keyed 1045 Steel Drive Shaft

- 1" diameter, 1/4" keyway width
- 18" length, passes through keyed drive roller and mounted ball bearings

8) Oil-resistant Keyed Drive Roller

(McMaster-Carr, Part #61065K17)

- 1" bore diameter for keyed steel drive shaft

10) C-channel Structural Steel Pieces (left and right)

- Bias-cut for welding to steel base plate at a 20° angle
- Steel cap welded to top to attach mounted ball bearing
- See detail at right

11) Flat Steel

- Dimensions: 3/8" thick, 10" x 10"
- Top plate supports two angled C-channel steel pieces



JOHN CULPEPPER jculpepper@northcountryschool.org
NORTH COUNTRY SCHOOL AND CAMP TREETOPS

ROTARY COMPOSTER

Compost Discharge End



12) 4' x 4' x 1/4" Steel End Cap

• This was cut from a 4' x 8' piece of steel purchased locally.

13) 12" x 12" x 1/8" Flat Steel

• This was cut from a larger piece

14) Rubber Cover

• These can be cut from any durable, bendable material

• Similar to diagram no. 7.

6) 3" x 6" x 3/16" Structural Steel

15) 1 1/2" x 3" x 3/16" Steel

16) Metal Wheel

(McMaster-Carr Part # 2442T33)



JOHN CULPEPPER jculpepper@northcountryschool.org
NORTH COUNTRY SCHOOL AND CAMP TREETOPS

ROTARY COMPOSTER

Keeper Wheel Frame

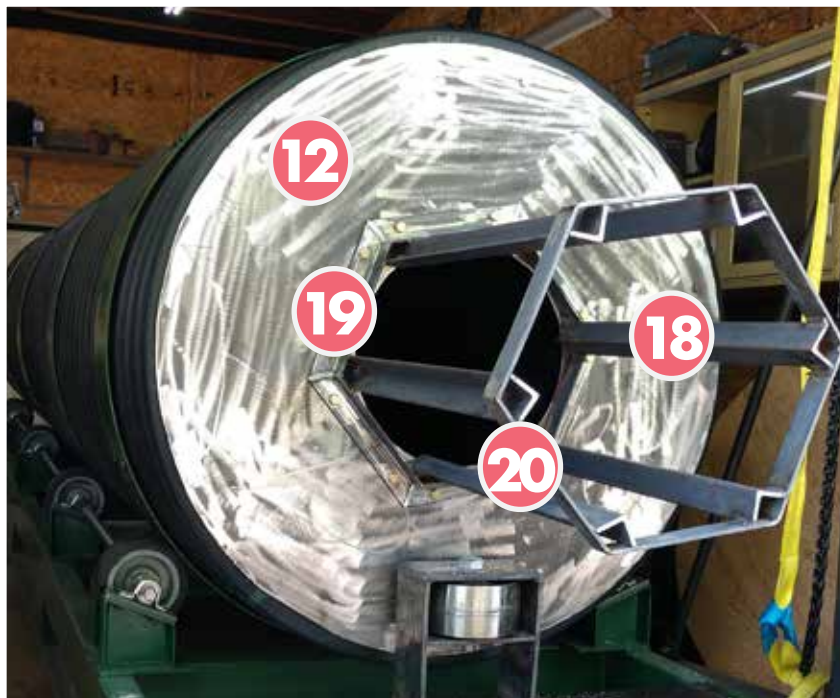

1) End Plate (from inside the drum)

12) 1/4" Steel End Plate (unpainted)

• Attached with 6 bolts through 3" x 3" flanges welded to 3" x 3" angle iron running inside the full length of the culvert. The end caps are bolted through these flanges.

17) Sheets of 1/2" expanded metal

• welded where they come together

18) 2" x 2" x 1/4" angle steel

19) 2" x 2" x 1/4" angle steel

20) 2" x 3/16" flat steel



ROTARY COMPOSTER

Loading Door End Cap



ROTARY COMPOSTER

End Cap and Loading Door



21) 3/4" Plywood End Cap

22) Plywood Door

- 3/4" thick marine-grade plywood
- Mounted with steel hinges to swing outward

23) Barrel Latch Closure

24) 5/8" Bolt, Grade 8

- Secure plywood end cap to 3" x 3" steel flanges that are welded onto the 3" x 3" angle iron pieces

25) 3/4" Marine Plywood

- Custom cut piece to which the barrel latch closure and hinges attach

26) Hinge

2) 3" x 3" Angle Iron

- Provides torsional and longitudinal stability, and efficient food scrap agitation when drum is rotated.

ROTARY COMPOSTER

Drive System



27) "Female end" of HDPE drum

28) 2HP Single Phase Trans-Power Motor

(Kamen Industrial Technologies Part # CL3516TM)

• If using a 3-phase motor, use a 2HP Trans-Power motor, model TPE2R18C/C145TC

8) Oil-resistant Keyed Drive Roller

(McMaster-Carr Part # 61065K17)

6) 3"x 6" x 3/16" Hollow Rectangular Structural Steel Frame

JOHN CULPEPPER jculpepper@northcountryschool.org
NORTH COUNTRY SCHOOL AND CAMP TREETOPS

ROTARY COMPOSTER

Drive System



29) Double-Strand Sprocket

(McMaster-Carr, Part #2784K25)

- For connecting two ANSI roller chain #40 between each large sprocket and motor/worm gear reducer.

30) ANSI #40 Chain (McMaster-Carr, Part #6261K173)

31) Steel support deck for motor and speed reducer

- 14½" x 20½" x ¾"

32) Boston Gear Worm Gear Speed Reducer

(Kaman Industrial Technologies, F738-60E-B7-J)

2) 2" x 2" x ¼" Angle Frame

33) Ball-bearing Idler Sprocket

(Kaman Industrial Technologies, Part # MSG40BB18H)

- ½" pitch, 18 teeth, 5/8" bore diameter,
- Provides tension to roller chain, compatible with ANSI roller chain #40

JOHN CULPEPPER jculpepper@northcountryschool.org
NORTH COUNTRY SCHOOL AND CAMP TREETOPS

ROTARY COMPOSTER

Drive System



10) C-shape Structural Steel Pieces (left and right)

- Bias-cut for welding to steel base plate at a 20° angle
- Steel cap welded to top to attach mounted ball bearing

6) 3" x 6" x 3/16" Cross Member

33) Ball-bearing Idler Sprocket

(Kaman Industrial Technologies, Part # MSG40BB18H)

- 1/2" pitch, 18 teeth, 5/8" bore diameter,
- Provides tension to roller chain, compatible with ANSI roller chain #40

28) 2HP Single Phase Motor

(Kamen Industrial Technologies Part # CL3516TM)

- If using a 3-phase motor, use a 2HP Trans-Power motor, model TPE2R18C/C145TC

JOHN CULPEPPER jculpepper@northcountryschool.org
NORTH COUNTRY SCHOOL AND CAMP TREETOPS

ROTARY COMPOSTER

Side View

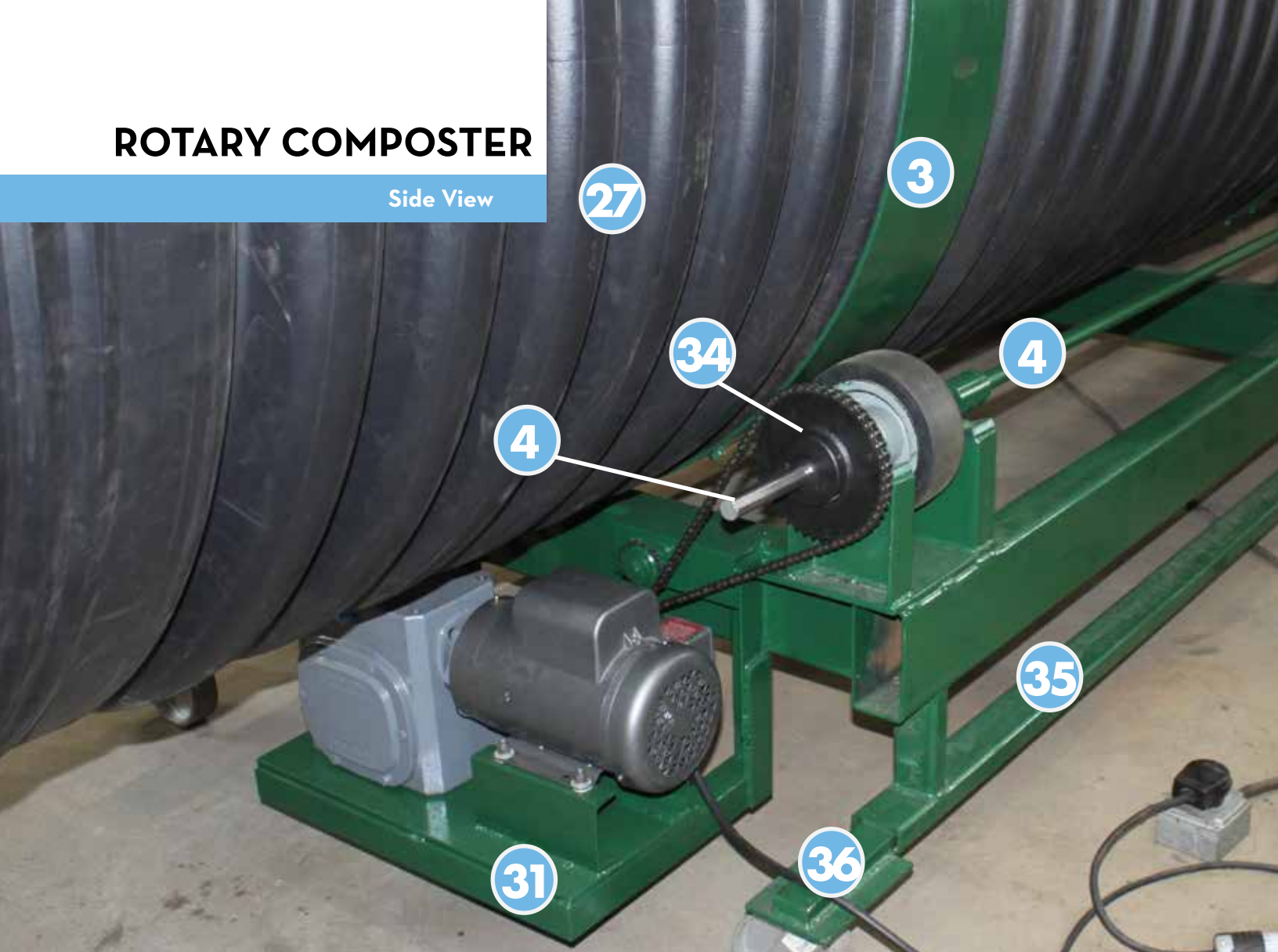

3) Steel Drum Bands

- 8" wide, 1/4" thick

4) Fully-Keyed 1045 Steel Drive Shaft

- Fully-keyed for use with high-grip clamp
- Connects ball-bearing/roller wheel assemblies along entire length of composter
- Cut such that the couplers are close to the wheel assembly
- Able to be cut shorter, if necessary

27) HDPE Culvert (Composter Drum)

- 4' diameter x 20' length, purchased locally

31) Deck for Motor and Gear Reduction Box

34) Finished-Bore Sprocket

(McMaster-Carr, Part #6236K361)

35) 1 1/2" x 3" x 3/16" Hollow Rectangular Structural Steel "Stiffening Bar"

36) Slide in Wheel

- This was custom built to allow the entire composter to be slid into a 40-ft shipping container. This piece is removed once the composter is set.

JOHN CULPEPPER jculpepper@northcountryschool.org
NORTH COUNTRY SCHOOL AND CAMP TREETOPS

ROTARY COMPOSTER

Parts and Quantities

DIAGRAM NO.	PART	QUANTITIES
1	3" x 1/4" flat stock steel	~10 ft.
2	3" x 3" x 1/4" angle iron	~120 ft.
3	8" x 1/4" x 54 1/2" flat steel, rolled	8
4	Fully-keyed steel drive shaft, 1" x 1/4" x 1/8" (cut so the couplers are close to wheel assemblies)	Two 20-ft. lengths
5	High-grip clamp-on rigid shaft coupling (McMaster-Carr, Part #9800T14)	6
6	3" x 6" x 3/16" hollow structural steel	~60 ft.
7, 14	Custom-made rubber covers (Can be cut from any durable, bendable material)	3
8	Oil-resistant keyed drive roller (McMaster-Carr, Part #61065K17)	8
9	Stamped-steel mounted ball bearing (McMaster-Carr, Part #5913K64)	16
10	C-channel structural steel, 2" x 6" x 3/16"	~6 ft.
11	10" x 10" x 3/8" flat steel	1
12	Steel end cap cut from 4' x 4' x 1/4" piece of steel	1
13	12" x 12" x 1/8" flat steel	1
15	1 1/2" x 3" x 3/16" hollow structural steel	Two 24'-ft. lengths
16	8" metal wheel (McMaster-Carr #2442T33)	1
17	1/2" expanded metal	One 4'x8' sheet
18	2" x 2" x 1/4" angle steel	16 ft.
19	2" x 2" x 1/4" angle steel	6 ft.
20	2" x 3/16" flat steel	6 ft.
21-22, 25	3/4" marine-grade plywood (for end cap, door and other support pieces)	~34 ft.
23, 26	Purchased from a local hardware store (one heavy-duty barrel latch closure and two hinges)	
24	5/8" x 2 1/2" bolts, grade 8	1
27	4' x 20' HDPE road culvert	12
28	Baldor 2HP Single Phase Motor (Kaman Industrial Technologies, CL3516TM)	1
29	Double-Strand Sprocket, 1 5/8" (Kaman Industrial Technologies, Part #MSG 40BS19)	1
30	ANSI #40 Roller Chain (McMaster-Carr, Part #6261K173)	~20 ft.
31	Steel support deck for motor and speed reducer: 14 1/2" x 20 1/2" x 3/8"	1
32	Boston Gear Worm Gear Speed Reducer (Kaman Industrial Technologies, BOS F738-60E-B7-J)	1
33	Ball-bearing Idler Sprocket, 5/8" (Kaman Industrial Technologies, MSG 40BB18H)	2
34	Finished-bore Sprocket (McMaster-Carr, Part #6236K361)	2
35	1 1/2" x 3" x 3/16" structural steel	2
MISC:	1/2" x 4" bolts, grade 8	80